

The background features a collage of various ProScale products, including scales, calipers, and digital displays, each enclosed within a semi-transparent sphere. The spheres are arranged in a scattered pattern across the page. The overall color scheme is light blue and white, with a subtle grid pattern in the background.

ProScale™

General Instruction Manual

Includes: ProScale Model 150 & 250

ProStop

Measurement Table Kits

ProPanel

ProCaliper

Digital Displays

Accurate Technology, Inc.

270 Rutledge Rd. Unit E

Fletcher, NC 28732 USA

800 233-0580 • 828-654-7920

Fax 828-654-8824

www.proscale.com

info@accurate-technology.com

Warranty

Accurate Technology, Inc., warrants this product against defective parts and workmanship commencing from the date of original purchase. Upon notification of a defect, Accurate Technology, Inc., shall have the option to repair or replace any defective part. Such services shall be the customer's sole and exclusive remedy. Expenses incidental to repair, maintenance, or replacement under warranty, including those for labor and material, shall be borne by Accurate Technology, Inc. Freight or transportation charges to Accurate Technology, Inc., shall be paid by the customer.

Except as expressly provided in this warranty, Accurate Technology, Inc., does not make any warranties in respect to the product, either expressed or implied, including implied warranties of merchantability or fitness for a particular purpose, except as expressly provided in this agreement.

Accurate Technology, Inc., shall not be liable for any special, incidental, or consequential damages or for loss, damage or expense directly or indirectly arising from the customer's use of or inability to use the equipment either separately or in combination with other equipment, or for personal injury or loss or destruction of other property, or from any other cause.

To request repair work (either warranty qualified parts or not), contact Accurate Technology, Inc. directly by phone, fax, or e-mail. A Returned Merchandise Authorization (RMA) number is required before returning a product for repair.

SAFETY WARNING

**Before installing ProScale products,
turn off the machine and disconnect it
from its power source to avoid injury.**

SAFETY WARNING

Revision B, P/N 800-1001-003. Copyright © 1999, Accurate Technology, Inc. All rights reserved.

Table of Contents

<u>SECTION 1 GENERAL INFORMATION</u>	5
Introduction	5
ProScale Technology	6
Scales-Incremental Vs. Absolute	7
Readheads	9
System Descriptions	10
Specifications	12
<u>SECTION 2 PRODUCTS</u>	14
ProScale Model 150	14
Mounting	14
ProScale Model 250	17
Mounting	17
ProStop	21
Assembly	21
Mounting	22
ProKits	24
Assembly	24
Measurement Table Kit	25
Assembly	25
ProPanel	27
Assembly	27
Operation	27
ProCaliper	29
Assembly	29
Mounting	29
Notes about Accuracy:	30
Operation	30
<u>SECTION 3 DISPLAY OPERATION</u>	32
Digital Display Descriptions	32
Basic and Incremental Displays	33
Standard and SPC Displays	36
1/4 DIN Panel Mount Displays	40
Programmable (Including Externally Powered Displays)	43
Summary of Digital Display Keypad Functions	46
Changing the Batteries	46
Mounting the Display	46

SECTION 4 MISCELLANEOUS.....47

Installation Notes.....47

 Scales.....47

 Readheads47

 Displays48

Incremental Display49

Basic Display49

Standard Display49

SPC Display.....50

Programmable Battery Display51

Programmable Ext. Pwr. Display51

Panel Mount Display.....52

Panel Mount Display.....53

ProPower DC Power Supply.....54

Frequently Asked Questions55

Error Codes & Factory Service56

Abbe Error57

Introduction

ProScale™ digital measuring systems are high-precision electronic devices for making linear measurements with speed and accuracy, consisting of a scale, a readhead (or encoder) mechanism and a digital display unit. ProScale uses patented capacitive encoder technology, the same technology used in high accuracy digital calipers.

ProScale is compatible with most machines used to dimension wood, metal, plastic or composite materials. For example, one could measure lengths and widths for a vertical-panel saw, set cutting depth for a router, or set the position of a traverse axis on a tenoner. Besides measuring linear distances, ProScale is ideal for setting the positions of fences, stops, and cutters.

Because ProScale shows the exact measurement on its display, it eliminates the guesswork involved in reading and interpreting tape, pointer, or shaft encoder scales. It also speeds up measurements. As a result, machine setup time can be reduced considerably, maximizing throughput on a machine.

ProScale's measurement mode can be changed at the touch of a key (most models). If accustomed to measuring in inches, ProScale can be set to measure in sixteenths, thirty-seconds, sixty-fourths, or even in thousandths of an inch. If accustomed to working with metric measurements, press a key to measure in millimeters. In any mode, ProScale is designed to provide and maintain its accuracy for years.

ProScale is extremely rugged and durable. Unlike optical measurement systems, the accuracy of capacitive systems is not affected by sawdust or other non conductive contaminants. Additionally, power consumption is much less than magnetic or optical measurement systems.

Because ProScale is a solid-state electronic device there's very little to wear out. The read head and scale are designed to withstand shop dirt, dust, and other airborne contaminants, and the controls are sealed with a protective cover for long life. With normal care, ProScale will last for years.

ProScale Technology

All ProScale systems consist of a **SCALE**, **READHEAD**, and a **DISPLAY**.

The **SCALE** consists of a series of conductive patterns on a non-conductive substrate. The **READHEAD** contains a computer chip which transmits and receives signals to the scale using capacitive coupling (without actually touching the scale). The received signal is used by the computer chip to calculate the **READHEAD** position to 0.01mm precision. This position data is sent to the digital **DISPLAY**, where it can be displayed in fractions, decimal inches, centimeters, or millimeters.

Each of the primary components is either for incremental measurement or for absolute measurement. (Absolute systems use a more robust and sophisticated method to measure position, resulting in a high immunity to electrical interference and one that does not forget its position.) In some cases, these technologies may be used together. Because not all ProScale systems utilize the same style scale, readhead, or display (incremental or absolute), it is very important to understand exactly which components your ProScale uses. First, you must know which product you have. This may be determined by the pictures and descriptions on the following pages of this manual, by reviewing our web site, by the label on the packaging, or by contacting your supplier.

Scales-Incremental Vs. Absolute

Simply stated, an **Incremental system** measures the distance it has traveled relative to a starting point.

An **absolute system** (*ABS*) measures its actual position by reading a pattern which is unique at any given location over its length. The maximum length of this pattern is 430mm (16.932 in.). The pattern must then repeat itself.



Consider the illustration above to represent a ProScale *ABS*. There are three absolute patterns (each pattern is 430mm long), joined together end to end. Within each pattern the system is totally absolute. However, crossing over a pattern joint now presents the readhead with information identical to what it read in the previous pattern. At this point the system must be able to recognize that it has crossed over a pattern joint and therefore must add or subtract the value of 1 **pattern offset**. In fact, each time the readhead passes over a pattern joint it must keep track of how many patterns it has passed, and in which direction. This process is accomplished by the software in the display.

What does all this mean? If the readhead remains on the same absolute pattern, it can have power removed, its position changed and power restored without loss of position information. ***However, if power is removed and the readhead passes over a pattern joint, the transition will not be recognized. When power is restored the system knows its absolute position on the new pattern, but does not know how many patterns it has passed, or in which direction!***

Displays used in **absolute systems** provide the operator with a method to adjust the pattern offset in the display memory so the system displays the correct reading at all times without loss of accuracy. See Section 3 for information about the different *ABS* displays and how to correct for pattern offsets.

All ABS style scales have a “zigzag” pattern etched onto the green laminate. **Take care to not damage this etching** or remove the green coating. There should also be a pattern “break” approximately every 430mm (17in.). **Do not attempt to shorten ABS style scales.**



Incremental style scales have a repeating “bar” pattern etched onto the green laminate. Take care not to damage the etched pattern, or remove the green coating. There should also be a pattern “break” approximately every 575mm (22.6in.). The Incremental style scales used in ProStop, ProKit, Measuring Kits, and ProPanel may be shortened if needed. For more detailed instructions, see the instructions on page 47.



Model 150 scales should be mounted to machinery using the supplied M5 (or 10-32) machine screw and Connector Link. This Connector Link is specially designed to flex slightly if there is any mechanical binding in the readhead-to-scale mounting. The Connector Link should always be mounted in the same direction as the scale (see the diagram on page 15). **Warranty is void if the Connector Link is not used.**

Model 250 scales were designed to be mounted on machinery using M4 (or 6-32) Flathead screws. Accurate Technology provides a Guide Clip to attach the readhead to a moving part of a machine see the diagram on page 18). **Warranty is void if the Guide Clip is not used.**

Readheads

ABS style readheads have “**BLACK END OF SCALE**” labels on the cover, and the telephone-style wire exits from the *corner* of the housing. Extreme care must be taken not to damage the six brass “fingers” inside the readhead housing. *ABS* style readheads, used in all Model 150 and Model 250 systems, **must** be mounted on *ABS* scales with a particular orientation. Each readhead has an arrow on the label pointing in the direction of the “**BLACK END OF SCALE**” (each *ABS* style scale will have one end painted black). This relationship is very important, since the readhead will work, but produce erratic results if incorrectly installed. To insure proper operation, be sure the arrow on the readhead is pointing toward the **BLACK** end of the scale. The standard readhead has 3m (10 ft.) of cable. For special cable lengths, contact Accurate Technology, Inc. The *ABS* style readheads are standard in the Model 150 and Model 250 systems.

Incremental style readheads do *not* have labels on the cover, and the telephone style wire exits from the *center* of the housing. Extreme care must be taken not to damage the twelve brass “fingers” inside the readhead housing. Incremental readheads may be mounted on incremental scales with any orientation. Incremental readheads are used in ProStop, ProKit, Measuring Kits, ProCaliper, and ProPanel.

System Descriptions

ProScale Model 150 systems use *ABS* style scales, *ABS* style readheads, and *ABS* style displays. Neither the scale nor readhead are *compatible* with Incremental style displays.



ProScale Model 250 systems use *ABS* style scales, *ABS* style readheads, and *ABS* style displays. Neither the scale nor readhead are *compatible* with Incremental style displays.



ProStop systems use Incremental style scales, Incremental style readheads, and *ABS* style displays. The *ABS* display has been modified to operate with the Incremental scale and Incremental readhead.



Measurement Kits use Incremental style scales, Incremental style readheads, and *ABS/SPC* style displays. The *ABS* display has been modified to operate with the Incremental scale and Incremental readhead.



ProPanel systems use Incremental style scales, Incremental style readheads, and *ABS/SPC* style displays. The *ABS* display has been modified to operate with the Incremental scale and Incremental readhead.



ProCaliper systems use Incremental style scales, Incremental style readheads, and *ABS* style displays. The *ABS* display has been modified to operate with the Incremental scale and Incremental readhead.



Other Accurate Technology System Descriptions

(See individual product manuals for detailed descriptions & operation for the products below)

ProKits use Incremental style scales, Incremental style readheads, and *ABS* style displays. The *ABS* displays have been modified to operate with the Incremental scale and Incremental readhead. See the installation and operation manual for your ProKit for more information.

ProSet uses *ABS* style scales, *ABS* style readheads, and special displays. See the Model 150 section for installation information. See the ProSet manual for operation information.

ProCase uses *ABS* style scales and *ABS* style readheads. The handheld pendant acts as a display unit for all scales. See the ProCase manuals for operation information.

ProStand uses Incremental style scales, Incremental style readheads, and Incremental style displays. See the ProStand manual for operation information.

ProTOOL uses the ProStand system with or without digital displays and a user supplied computer with monitor.

ProTable uses Incremental style scales, Incremental style readheads, and *ABS* style SPC displays.

ProLine uses Incremental style scales, Incremental style readheads, *ABS* style displays and Carter Products Laser Diode Guide Lights.

ProPower is a multi voltage input and multi voltage output power supply used to power up to 10 LED digital displays or up to 50 LCD digital displays.

Specifications

Accuracy: $\pm .165\text{mm}$ per meter to $\pm .2\text{mm}$ max. error
 $\pm .002\text{in}$ per foot to $\pm .008\text{in}$ max. error

Repeatability: 0.01mm or .001in.

Max. Slew Rate:

Model 150: 450 mm/sec. (18 inches/sec.)
Model 250: 450 mm/sec. (18 inches/sec.)
ProStop: 600 mm/sec. (24 inches/sec.)
ProKits: 600 mm/sec. (24 inches/sec.)
Measuring Kits: 600 mm/sec. (24 inches/sec.)
ProPanel: 600 mm/sec. (24 inches/sec.)
ProCaliper: 600 mm/sec. (24 inches/sec.)

Display Range: $\pm 9999.99\text{ mm}$, $\pm 394.000\text{ in}$, $\pm 99\text{ }^{63/64}$

Power:

Model 150: Varies with display option ordered.
Model 250: Varies with display option ordered.
ProStop: Two AA Alkaline Batteries
ProKits: Two AA Alkaline Batteries
Measuring Kits: Two AA Alkaline Batteries
ProPanel: Two AA Alkaline Batteries
ProCaliper: Two AA Alkaline Batteries

Battery Life:

Model 150: Varies with display option ordered.
Model 250: Varies with display option ordered.
ProStop: One year with normal use.
ProKits: One year with normal use.
Measuring Kits: One year with normal use.
ProPanel: One year with normal use.
ProCaliper: One year with normal use.

Warranty:

Model 150: Three years from date of purchase
Model 250: Three years from date of purchase
ProStop: Two years from date of purchase
ProKits: Two years from date of purchase
Measuring Kits: Two years from date of purchase

ProPanel:	Two years from date of purchase
ProCaliper:	Two years from date of purchase
Operating Temperature:	0 to 51°C/ 32 to 120°F
Output Format:	SPC display: Mitutoyo SPC format. ProScale may be connected to a computer or data logger. Call Accurate Technology, Inc. for more information.
Cable:	Six-conductor, terminated by RJ12 modular connector. To increase or decrease cable length, contact Accurate Technology.
Dimensions:	All product dimensions available upon request.



ProScale Model 150

ProScale Model 150 systems are general purpose absolute measuring systems designed for taking measurements less than 450mm (18in.).

ProScale is easy to install. By following the basics of good installation in this section, reliable, error-free operation is assured. Because ProScale can be installed on many different types and brands of equipment, all installations will be a little different. Therefore, it's the responsibility of the installer to choose the bolts, screws, or other mounting hardware that guarantee proper installation for optimum operation.

Note: If a kit was ordered which contains instructions for installing ProScale onto a specific product, follow those instructions rather than the general instructions here.

Mounting:

1. Note the orientation of the readhead on the scale. Be sure the arrow on the readhead points towards the **“BLACK END OF SCALE”**. This orientation is critical for proper operation of ProScale. Be sure the mounting location for the readhead and scale will allow this orientation.
2. Determine an appropriate mounting location for the system. The readhead should be mounted to a **stationary** part of the machine. The scale should be mounted to the **moving** part of the machine with the connector link. Be sure to allow sufficient space to accommodate the connector link, which is used to mount the scale to the moving part of the machine.



Connector Link

The Display should be mounted in a location which allows for easy viewing by the machine operator. The location of the parts should also safeguard the cable from possible damage. All ProScale wiring should be kept as far away as possible from the machine's wiring and motors and dust collection systems. Avoid running the readhead wiring parallel to high voltage/current wiring.

3. Mount the readhead using three screws or bolts. It may be necessary to use washers or spacers to ensure a good mount (if the readhead is to be mounted on an uneven surface).
4. Check that the scale is properly aligned with the direction of motion of the moving part. The connector link will compensate for only a small amount of misalignment. The connector link **must** be mounted in the same direction as the scale (as in the figure below).
Note: Failure to use the connector link will void the warranty.
5. Mount one end of the connector link to the scale using an M5 (or 10-32) screw and the other end to the moving part of the machine. Check that both connections are very secure; inaccurate/erratic readings may otherwise occur.
6. Plug the readhead into the display. See Section 3 regarding mounting and use of different display versions.

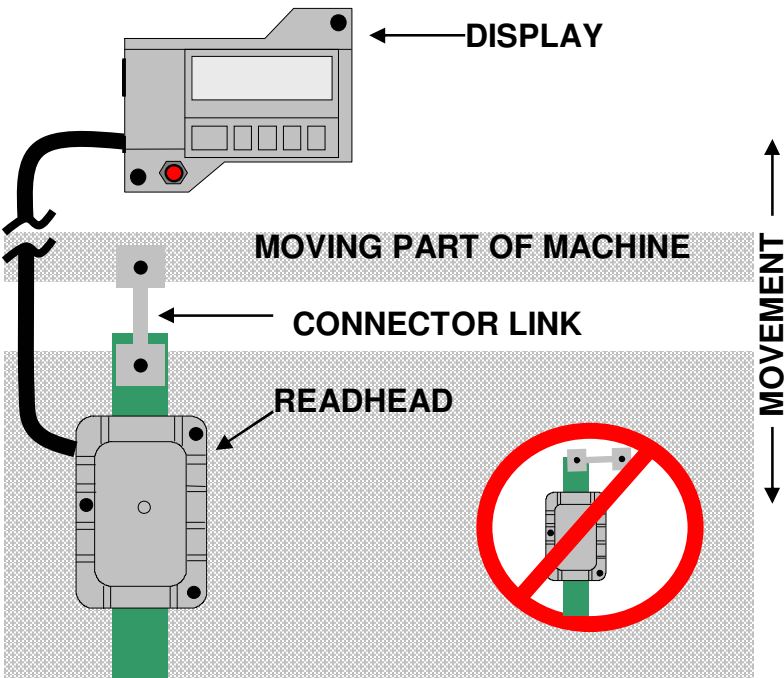

A Typical Model 150 Installation

Calibration:

Once installed, ProScale can be calibrated easily and quickly. Following is an example for calibrating ProScale on an industrial sander. Other installations follow the same general procedure.

1. Check to be sure installation of all parts is complete, all fasteners are secure, and the display is plugged in.
2. Set the machine to sand as normal. Using the regular operation, run a part through the sander.
3. Measure the thickness of the sanded part with the most precise measuring tool available (digital calipers if possible).
4. Press the zero key on the ProScale digital display.
Note: If the direction of movement and the direction shown on the digital display are opposite, the position of internal jumper JP3 should be changed. See Section 3 for more information.
5. Press and hold the PLUS key to scroll until the thickness measurement is displayed (the longer the PLUS key is held down, the faster the display will scroll).
6. When the proper reading is reached, lock the display if desired. This prevents accidentally re-zeroing of the display. See Section 3 for more information about how to lock the display.
7. Re-calibrate, if necessary, after changing sanding belts (or applicable tooling).
8. Calibration is not necessary after batteries are changed.

Maintenance:

The aluminum scale should be cleaned of debris often. This will prevent premature damage to the scale or readhead. Should the scale become difficult to move, check that it is thoroughly cleaned. Find and remove any burrs which may have developed on the aluminum scale. Do not use any liquid lubricants on the scale assembly, as this may:

1. Impede the readhead's ability to operate properly.
2. Attract other contaminants to the scale.

The Digital Display should be cleaned periodically with compressed air to remove any dust on the lens and keys. All mounting fasteners should be checked occasionally for tightness.



ProScale Model 250

ProScale Model 250 systems are general purpose absolute measuring systems designed for taking measurements up to 6.0m (236in.).

ProScale is easy to install. By following the basics of good installation in this section, reliable, error-free operation is assured. Because ProScale can be installed on many different types and brands of equipment, all installations will be a little different. Therefore, it's the responsibility of the installer to choose the bolts, screws, or other mounting hardware that guarantee proper installation for optimum operation.

Note: If a kit was ordered which contains instructions for installing ProScale onto a specific product, follow those instructions rather than the general instructions here.

Mounting:

1. Note the orientation of the readhead on the scale. Be sure the arrow on the readhead points towards the “**BLACK END OF SCALE**”. This orientation is critical for proper operation of ProScale. Check to be sure the mounting location for the system will allow this orientation.
2. Determine an appropriate mounting location for the system. The scale should be mounted to a **stationary** part of the machine. The readhead slides along the scale, using the supplied guide clip to translate machine movement to readhead movement. The Display should be mounted in a location which allows for easy viewing by the machine operator. The location of the parts should also safeguard the cable from possible damage. All ProScale wiring should be kept as far away as possible from the machine's wiring and motors. Avoid running the readhead wiring parallel to high voltage/current wiring or dust collection systems.



Guide Clip

3. Mount the scale using M4 (or #6) screws. It may be necessary to use washers or spacers to ensure a good mount if the scale is to be mounted on an uneven surface. Be sure the screw heads do not protrude above the surface of the extrusion. If they do, they will interfere with the readhead.
 - a. Check that the scale is properly aligned with the direction of motion of the moving part (any error in alignment will be magnified by the digital components, and could cause premature failure). Adjust the scale alignment if necessary.
4. Referring to the figure, note these two installation requirements:
 - a. For accurate measurements, the guide clip should be mounted perpendicular to the direction of travel of the readhead.
 - b. Over the full range of travel, the guide clip should exert some pressure on the readhead so the two move as a single unit.

Note: Failure to use the guide clip will void the warranty.

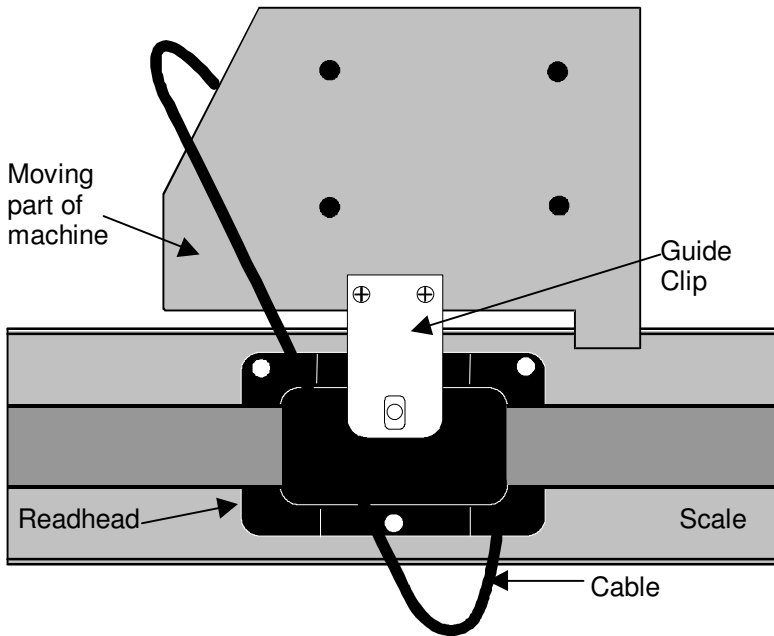

Typical Model 250 Installation

5. Reinstall the readhead if it has been removed from the scale. Care should be taken to not damage the readhead's sensitive internal ground fingers. Also note the orientation label on the readhead housing. Carefully slide the readhead onto the scale, checking for the proper orientation.
6. Slide the readhead until it meets and engages with the guide clip. Check that the guide clip exerts sufficient pressure on the readhead, as seen in the figure below.

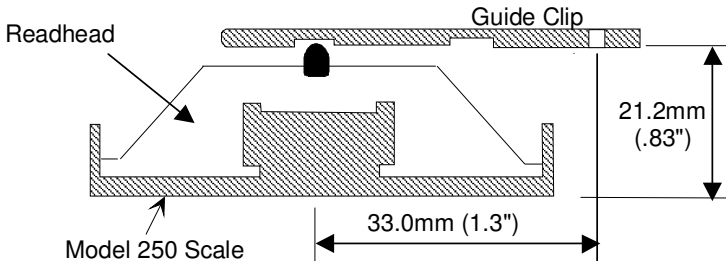

Guide Clip Pressure/Spacing (End View)

7. Place the cable in a secure position. If necessary, fasten it with a wire tie or other fastening device. Do not leave the cable where it could be damaged or pulled from the readhead. If the application requires over twenty feet of cable, the display may need to be modified for proper operation. Also, if the application requires a shorter scale, please call Accurate Technology for assistance.
8. Plug the readhead into the display. See Section 3 regarding mounting and use of different display versions.

Note: If any other mounting method is used, observe the following:

- a. *Do not drill through the green portion of the scale at any point over which the readhead will travel.*
- b. *Do not mount the scale so the mounting hardware interferes with the movement of the readhead.*

Calibration:

Once installed, ProScale can be calibrated easily and quickly. Following is an example for calibrating ProScale on a table saw fence. Other installations follow the same general procedure.

1. Check to be sure installation of all parts is complete, all fasteners are secure, and the display is plugged in.
2. Cut a part using the normal operation.

3. Measure the length of the part with the most precise measuring tool available (i.e. digital calipers).
4. Press the zero key on the ProScale digital display.
Note: If the direction of movement and the direction shown on the digital display are opposite, the position of internal jumper JP3 should be changed. See Section 3 for more information.
5. Press and hold the PLUS key to scroll until the length measurement is displayed (the longer the PLUS key is held down, the faster the display will scroll).
6. When the proper reading is reached, lock the display if desired. This prevents accidentally re-zeroing of the display. See Section 3 for more information about how to lock the display.
7. Re-calibrate, if necessary, after changing saw blades (or applicable tooling).
8. Calibration is not necessary after batteries are changed.

Maintenance:

The aluminum scale should be cleaned of debris often. This will prevent premature damage to the scale or readhead. Should the readhead assembly become difficult to move, check that the scale is thoroughly cleaned. Find and remove any burrs which may have developed on the aluminum scale. Do not use any liquid lubricants on the scale assembly, as this may:

1. Impede the readhead's ability to operate properly.
2. Attract other contaminants to the scale.

The Digital Display should be cleaned periodically with compressed air to remove any dust on the lens and keys. All mounting fasteners should occasionally be checked for tightness. If there is any wear on the green laminate of the scale, the guide clip pressure on the readhead should be reduced. If wear continues, the readhead bearing should be replaced.



ProStop

ProStop is a complete digital stop and fence system for chop saws, radial arm saws, and miter saws.

ProStop is easy to install. By following the basics of good installation in this section, reliable, error-free operation is assured. Because ProStop can be installed on so many different types and brands of equipment, all installations will be different. Therefore, it's the responsibility of the installer to choose the bolts, screws, or other mounting hardware that guarantee proper installation for optimum operation.

Assembly:

Each ProStop shipped from Accurate Technology will have at least two packages. The first contains the linear scale and fence extrusion. The second package contains the digital stop, an anti-tearout block, and mounting hardware. These parts should be assembled prior to mounting the ProStop.

1. Readhead installation: Note the readhead's sensitive internal ground fingers. Carefully slide the readhead onto the scale (see diagram on next page).
2. Stop Installation: Loosen the locking knob and slide the stop into the fence extrusion.
3. Slide the readhead up to the stop and slip the guide clip over the post on the readhead.
4. Display Installation: The display should be mounted to the aluminum block on the stop using the enclosed Velcro. Plug the readhead into the display.
5. Next, move the stop assembly left to right and note if the ProStop readings increase or decrease. Depending upon the installation (left

or right infeed), it may be necessary to change the position of JP3 inside the digital display to reverse the reading direction. (See section 3 regarding display jumper settings.)

Mounting:

1. Position the fence system so it is as close to 90 degrees with respect to the blade as possible.
2. The included installation nuts fit the T-slot in the bottom of the fence extrusion. These nuts can be used with the included bolts to mount the ProStop from the bottom.
3. The anti-tearout block (oak piece with bolts and nuts) can be used if the ProStop will be cutting parts where tearout is a problem. The block should be installed on the face of the fence extrusion, with the nuts inside the T-slot on the front of ProStop.

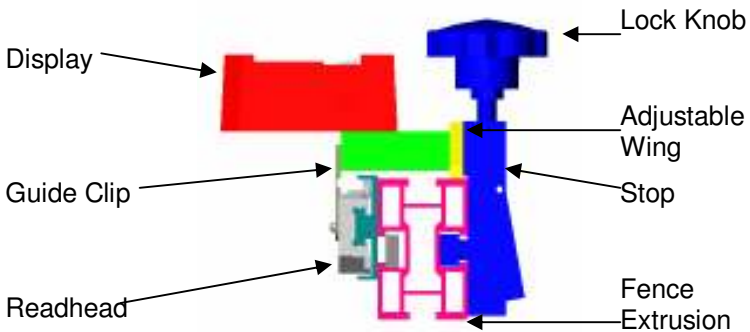

ProStop End View (shading shown is for clarity only)

Calibration:

Once installed, ProStop can be calibrated easily and quickly. Following is an example of calibrating ProStop for a cutoff saw application. Other installations follow the same general procedure.

1. Check to be sure installation of all parts is complete, all fasteners are secure and the display is plugged in.
2. Cut a part using the normal operation.
3. Measure the length of the part with the most precise measuring tool available (i.e. digital calipers).
4. Press the zero key on the ProScale digital display.

5. Press and hold the PLUS key to scroll until the measurement is displayed (the longer the PLUS key is held down, the faster the display will scroll).
6. When the proper reading is reached, lock the display if desired. This prevents accidentally re-zeroing of the display. See Section 3 for more information about how to lock the display.
7. Re-calibrate, if necessary, after changing saw blades (or applicable tooling).
8. Calibration is also necessary after display batteries are changed.

Maintenance:

1. The fence extrusion should be cleaned of all debris periodically. Do not use any liquid lubricants on the scale assembly, as this may:
 - a. Impede the readhead's ability to operate properly.
 - b. Attract other contaminants to the scale.
2. Should the stop become difficult to move, and the fence and scale have both been cleaned, the plastic wing may need adjustment:
 - a. Position the wing to hold the locking mechanism of the stop in the center of the extrusion slot.
 - b. The position of the wing can be adjusted after removing the plastic guide clip and loosening the socket screws (using a 3/16" hex wrench) which sandwich the wing between the stop and the aluminum block.
 - c. The wing is adjusted properly when the weight of the stop is supported by the wing and the locking mechanism does not rub on the extrusion.
3. The Digital Display should be cleaned periodically with compressed air to remove any dust on the lens and keys. All fasteners should occasionally be checked for tightness.
4. To change the batteries, remove the two screws that hold the cover to the base of the digital display. Remove the top cover carefully. Install two AA size alkaline batteries, noting the proper orientation shown in the battery compartment. Replace the cover and tighten the screws.





ProKits

ProKits are easy to install. By following the basics of good installation, reliable, error-free operation is assured. Because individual machines may have different manufacturing dates and/or castings, some installations may differ, and require hardware not provided by Accurate Technology. In these cases, it's the responsibility of the installer to choose the additional bolts, screws, or other mounting hardware that guarantee proper installation and optimum operation.

Assembly:

Each ProKit shipped from Accurate Technology will have at least two packages. The tubes contain the linear scales. The boxes contain the hardware, brackets, digital components, and installation instructions. Some parts may have been assembled prior to shipping.

Follow the installation instructions in the box to install the ProKit. Use this manual as a reference for information concerning the digital components and their use. Depending upon the installation, it may be necessary to change the position of JP3 inside the digital display to reverse the reading direction. (See section 4 regarding display jumper settings.) After the ProKit's digital scale has been positioned, it is very important to check that the scale is mounted in the exact direction of the desired measurement, as measuring errors will result if the digital scale is misaligned.

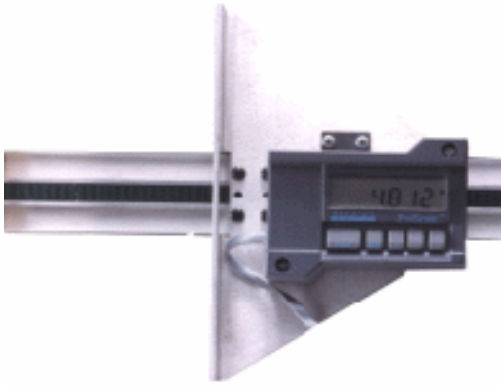

Measurement Table Kit

Measuring Table Kits are easy to install. By following the basics of good installation in this section, reliable, error-free operation is assured. Because Measuring Table Kits can be installed in so many different configurations, all installations will be slightly different. Therefore, it's the responsibility of the installer to choose the bolts, screws, or other mounting hardware that guarantee proper installation for optimum operation.

Note: If a kit was ordered which contains instructions for installing Measuring Table Kits onto a specific product, follow those instructions rather than the general instructions here.

Assembly:

Each Measuring Table Kit shipped from Accurate Technology will have at least two packages. The first contains the linear scale. The second contains the sliding assembly, and some mounting hardware. These parts should be assembled prior to mounting the Measuring Table Kit.

1. Remove the readhead from the scale.
2. Remove the front cover from the ProScale display.
3. Carefully drill the threads out of the brass inserts in the bottom cover, with a 3/16" (or equivalent) drill.
4. Remove the guide clip attached to the sliding assembly.
5. Note the readhead's sensitive internal ground fingers. Place the readhead into the sliding assembly cutout and carefully slide the unit onto the aluminum scale.
6. Reattach the guide clip to the sliding assembly.
7. Mount the display (top and bottom re-assembled) onto the sliding assembly using the supplied #8-32 x 1 3/4" screws and spacers. The spacers are inserted between the display and the moving assembly.

8. Plug the readhead into the display. Move the assembly from left to right and note if the display's readings increase or decrease. Depending upon the installation, it may be necessary to change JP3 inside the digital display to reverse the reading direction. (See section 3 regarding display jumper settings.)
9. After the Measurement Table Kit has been assembled, it is very important to check that the scale will be mounted in the **exact direction** of the desired measurement, as measuring errors will result if the scale is not properly aligned. See "Abbe error" on page 57 for more information.
10. Mount the scale using M4 (or #6) Flathead screws. Check that the backstop is solid and will not move under pressure. The scale may be recessed if desired; the cutout for the scale should be at least 2.02 inches wide for the full length of the aluminum scale.

Maintenance:

The digital scale should be cleaned of all debris often. This will prevent premature damage to the scale or readhead. Should the assembly become difficult to move, check that the scale is thoroughly cleaned. Find, and remove any burrs which may have developed on the aluminum scale. Do not use any liquid lubricants on the scale assembly, as this may:

1. Impede the readhead's ability to operate properly.
2. Attract other contaminants to the scale.
3. Swell the black bearings on the moving assembly, thus making the assembly tighter on the scale.

The Digital Display should be cleaned periodically with compressed air to remove any dust on the lens and keys. All fasteners should be checked occasionally for tightness. If there is any wear on the green laminate of the scale, the guide clip pressure on the readhead should be lessened. If wear continues, the readhead bearing should be replaced.

NOTE:

Completely assembled measurement systems are also available from Accurate Technology

- | | |
|--------------|------------------------------------|
| ProTable I | Single Axis Measurements |
| ProTable II | Two Axis Measurements |
| ProTable III | Three Axis Coordinate Measurements |



ProTable I



ProPanel

ProPanel is a portable measuring system capable of edge-to-edge, edge-to-hole, hole-to-hole, and corner-to-corner measurements up to 1.2m (48in.).

ProPanel is easy to use. By following the instructions in this section, reliable, error-free operation is assured.

Assembly:

ProPanel is assembled at the factory. If using the ProPanel to measure hole-to-edge or hole-to-hole distances, install the provided cones using the enclosed hex wrench.

Operation:

Edge-To-Edge Measuring:

Use ProPanel like a T-square. Close the jaws, and take the measurement.

Note: Do not use the outer edges of the jaws for measurements. If possible, use the full width of the jaw for reliable measurements.

Corner-To-Corner Measuring:

Place the ProPanel jaws over the panel corners. Gently "wiggle" the ProPanel while applying light closing pressure to seat the corners. Change to Incremental mode by pressing the red button on the display. (Press the zero key to zero the display if necessary.) Measure the second diagonal. The difference in diagonal lengths will be shown on the display. If the diagonal measurements are equal and any two adjacent edges are equal, then the panel is square. Press and hold the red button on the display for three seconds to return to Absolute mode.

Hole-To-Hole Measuring:

Install the two full cone attachments. Close the ProPanel. Use the plus or minus keys to adjust the display to exactly 38.1mm (1.500 inches). Place the cones into the holes to be measured. Be sure the cones are fully seated in the holes. Do not press down on the rail of the ProPanel, as this may affect accuracy.

Edge-To-Hole Measuring:

Install one full cone attachment and one half cone attachment. Close the ProPanel. Use the plus or minus keys to adjust the display to exactly 19.05mm (.750 inches). Place the full cone in the hole and the half cone against the edge of the panel. Keeping the ProPanel rail equidistant from the panel (by adjusting the half cone's position up or down) will assure the highest accuracy measurement.

Maintenance:

Occasionally check parallelism of the jaws by measuring a thick piece of paper on the upper side of the jaws, then on the lower side of the jaws. A variation of 0.05mm (0.002 inches) is acceptable. Use a precision square to adjust if necessary. The digital scale should be cleaned of all debris often. This will prevent premature damage to the scale or readhead. Should the assembly become difficult to move, check that the scale is cleaned. Find, and remove any burrs which may have developed on the aluminum scale. Do not use any liquid lubricants on the scale assembly, as this may:

1. Impede the readhead's ability to operate properly.
2. Attract other contaminants to the scale.
3. Swell the black bearings on the moving assembly, thus making the assembly tighter on the scale.

The Digital Display should be cleaned periodically with compressed air to remove any dust on the lens and keys. All fasteners should be checked occasionally for tightness. If there is any wear on the green laminate of the scale, the guide clip pressure on the readhead should be lessened (if wear continues, the readhead bearing should be replaced.)



ProCaliper

ProCaliper is easy to install and use. By following the installation instructions in this section, reliable, error-free operation is assured, with only an occasional need for adjustments or realignment of the jaws.

Assembly:

1. The jaws can be attached to the caliper in either of two positions. They may be mounted on the upper or lower side of the lip on each of the fixed or moving heads.
2. Loosely attach the left (fixed head) jaw to the caliper using the supplied socket screws. Square the jaw to the caliper rail with a machinist's square. Carefully tighten the screws, taking care to keep the jaw square to the rail.
3. Loosely attach the right jaw (moving head) to the caliper using the supplied socket screws. Slide the moving head up to the fixed head until the measuring surfaces of the two jaws touch.
4. While holding the jaws together, carefully tighten the screws on the moving jaw.
5. Using a feeler gauge, check for misalignment between the jaws near the tip and the heel of the jaws. If a gap of more than 0.05mm (0.002 inches) exists between the jaws at either point, loosen the screws and repeat steps 2 through 4.

Mounting:

1. Determine an appropriate mounting surface for the ProCaliper. Ideally, it should be mounted on an open, flat surface which does not interfere with the moving head.
2. Notice the three 1/4-20 mounting holes in the bottom of ProCaliper. Determine the depth of the mounting surface. Mount the rail to the surface using bolts of the appropriate length, making certain it is

mounted without any bending stress to the rail, which will cause measuring inaccuracies.

3. Check that the bolts extending through the rail will not interfere with the operation of the moving head. To provide the best accuracy, provide large clearance holes in the mounting surface, and shim all gaps precisely.

Notes about Accuracy:

ProCaliper has been thoroughly tested for accuracy against national standards. This test data has been supplied. However, the following situations can affect ProCaliper's overall accuracy. The specified accuracy of $\pm 0.05\text{mm}$ (0.002 inches) per measured foot is achieved at the heel (rail side) of the jaws. In some cases, this specified level of accuracy may be exceeded at the tip of the jaws. This difference results from the large distance between the center of the measuring scale inside the caliper rail and the tips of the caliper jaws. Small changes in temperature can cause slight differences in a given measurement. Because ProCaliper's major components are made from aluminum, which has a temperature coefficient of 23ppm/°C, it is strongly suggested to use ProCaliper in a temperature stable environment (over the 2400mm [96 inch] measuring range, this coefficient can alter measurements by 0.05mm [0.002 inches] per °C).

Operation:

1. Insert the object to be measured between the caliper jaws. While holding the object against the measurement face of the fixed jaw, slide the right jaw to the other end of the object until it stops.
2. Press in and rotate the fine adjustment thumb-wheel until the moving jaw is tight against the object. If the position of the moving jaw needs to be held in place, use the lock knob on the top of the moving head.
3. If not using the ProCaliper with SPC data collection devices, press the black button on the display to HOLD the displayed value. All of the display's operations will be stopped until the black button is pressed again.
4. Read the measurement data from the ProCaliper's display. The displayed data can now be sent to an SPC data collector/processor (if attached) by pressing the black button.

To Make Relative Measurements:

Measure the first part. Change to Incremental mode by pressing the red button on the display. Press the zero key. Measure the second part. The difference in length will be shown on the display. When finished taking relative measurements, press and hold the red button on the display for three seconds to return to Absolute mode.

Tips for Measuring Long Parts:

1. When measuring long parts, keep them parallel to the caliper rail (and as close as possible).
2. Support the object being measured so it is as straight as possible.

Maintenance:

ProCaliper must be kept clean to measure accurately. The measuring edges of the jaws and the bearing ways must be kept free of dust, dirt, and other residue. Clean often using a nonabrasive cleaner. Inconsistent measurements often indicate ProCaliper's jaws or bearings need realignment or adjustment. The Digital Display should be cleaned periodically with compressed air to remove any dust on the lens and keys. All fasteners should be checked occasionally for tightness. Periodically check the jaw alignment, particularly after rough or prolonged use.

Checking Bearing Adjustment:

ProCaliper's moving head has four white, cylindrical bearings which help it to slide easily along the caliper rail. These bearings, made of UHMW plastic, slide in grooves located on the front and rear of the caliper rail. The two bearings on the rear side have small spring plungers which keep the moving head at a constant distance from the caliper rail. The spring load on the bearings may have to be adjusted after prolonged use. To adjust the load, loosen the lock nuts on the spring plungers several turns. Tighten each spring plunger until the spring bottoms out. Loosen each screw 1/2 turn, then tighten the lock nuts. Check for smooth sliding operation and adjust again if necessary.

SECTION 3

DISPLAY OPERATION

Digital Display Descriptions

Accurate Technology makes several digital displays for use with its products. All displays have the same five keys (ON/OFF, MODE, +, ZERO, and -), and in some cases, some extra buttons. The following is a listing of the displays and their options:

<u>Display Description</u>	<u>Extra Buttons</u>	<u>Feature(s)</u>
Incremental Display (P/N 701-1495-002)	<i>none</i>	Used w/ incremental systems. Standard on older systems, such as Model 100/200.
Basic Display (P/N 701-1495-001)	<i>none</i>	No SPC, No HOLD Can be used for Model 150/250.
Standard Display (P/N 701-1500-001)	1 red	Absolute/Incremental readings Standard on ProStop, ProKits. Can be used for Model 150/250.
SPC Display (P/N 701-1505-002)	1 red, 1 black	Absolute/Incremental readings, and 10-pin SPC Output. Standard on ProPanel, ProCaliper, and Measuring Kits. Can be used for Model 150/250.
1/4 DIN Panel Mount (P/N 701-1550-002)	<i>none</i>	Absolute systems only. Panel Mounting Enclosure. Operates on "D" size alkalines. Can be used for Model 150/250.
1/4 DIN Panel Mount (P/N 701-1525-001)	<i>none</i>	For use with Model 150 only. Panel Mounting Enclosure. Operates on 24V AC or DC.
Programmable Display (P/N 701-1115-001)	<i>none</i>	Absolute/Incremental readings. Display is user programmable. Can be used for Model 150/250.
External Power (P/N 701-1115-002)	<i>none</i>	Uses ProPower™ for operation Can be used for Model 150/250.

It is very important to use the correct instructions for each display version, as each display operates somewhat differently.

The positions of the internal jumpers may be changed to limit the available display options or change the resolution. See the display options charts starting on page 48 for more information.

Basic and Incremental Displays



Changing the Measurement Readout:

Press the MODE key to change the measurement readout. The current measurement readout is saved when power is off. Readouts appear in the following order:

1. mm.
2. Decimal inches.
3. 16ths of an inch, each bar in the display's upper right corner represents an additional $1/64^{\text{th}}$ of an inch.
4. 32nds of an inch, each bar in the display's upper right corner represents an additional $1/64^{\text{th}}$ of an inch.
5. 64ths of an inch.

Setting Zero

A zero point is easily established by pressing the ZERO key when the display is unlocked. All subsequent measurements will reflect distance from this point.

Incrementing/Decrementing the Display

The PLUS or MINUS keys on the digital display are used to adjust a reading. For instance, if the display needs to read greater than its current value, use the PLUS key. Conversely, to reduce the current displayed reading, use the MINUS key. This function is used to preset a value in the system. When the display is in the locked mode these keys will either:

1. No longer function, preventing accidental adjustment of readings, or
2. They will be used for another function: pattern offset (only in the Basic displays).

Note: When pressing the PLUS or MINUS keys, the display scrolls slowly for a couple seconds and then speeds up.

Reverse Scaling

When setting a zero point on ProScale, moving the scale (or readhead) in one direction will produce positive readings. Moving the scale past zero in the opposite direction will produce negative readings. Reverse scaling means changing the orientation so the positive readings become negative and negative readings become positive. To reverse the readings, the position of JP3 (inside the display) must be changed. See the chart of Display Options for more information.

Auto Save

When power is turned off, ProScale remembers the current measurement and current mode of operation. When ProScale is turned back on, the user can continue where they left off. It's not necessary to zero the reading or change the mode. Also, keystrokes are not recognized when power is off, so accidental keystrokes will not change the stored information.

Locking the Keypad

The display allows the user to lock the keypad so the current settings can't be accidentally changed by depressing the ZERO, PLUS or MINUS keys. To lock the keypad proceed as follows:

1. While depressing and holding the ON/OFF key, momentarily press the MODE key.
2. Release the MODE key and then the ON/OFF key. The display should now indicate "LOCK" in the upper left corner.
3. Use the same procedure to UNLOCK the keypad.

Note: Locking the keypad may cause the PLUS and MINUS keys to function differently. (See "Pattern Adjustment".) The zero key will not function when the display is locked.

Pattern Adjustment (Basic Display Only)

Whenever the readhead is disconnected from its power source, *or the display is turned off*, and the readhead is moved over a pattern joint, the displayed reading may be one or more patterns ($\pm 430\text{mm}$) in error when power is restored. This may also occur if the readhead is moved too quickly in Model 150/250 systems.

To correct the error, place the digital display in ABS LOCK mode and use the PLUS or MINUS keys to increment or decrement the reading until the proper reading is displayed. Using this procedure will result in NO LOSS OF ACCURACY to the system.

Changing the Batteries

To change the batteries, remove the two screws holding the cover to the base of the display housing. Carefully pull off the cover. Remove the batteries. Reinstall new ones, noting the proper orientation shown in the battery compartment. Replace the cover and tighten the screws.

Note: DO NOT ATTEMPT TO BEND BATTERY CLIPS!

Mounting the Display

There are four small mounting holes in the back of the display which may be tapped for M2 or 4-40 screws. The display may also be mounted using double sided tape or Velcro.

Standard and SPC Displays



Changing the Measurement Readout:

Press the MODE key (while in ABS mode) to change the measurement readout. The current measurement readout is saved when power is off. Readouts appear in the following order:

1. mm.
2. Decimal inches.
3. 16ths of an inch, each bar in the display's upper right corner represents an additional $1/64^{\text{th}}$ of an inch.
4. 32nds of an inch, each bar in the display's upper right corner represents an additional $1/64^{\text{th}}$ of an inch.
5. 64ths of an inch.

Setting ABS Position

When the display is in ABS mode (indicated by ABS in the upper left corner of the display), a zero point is established by pressing the ZERO key. All subsequent absolute measurements will reflect distance from this point. The display should be locked to prevent accidental resetting.

Setting INC Position

Momentarily press the ABS/INC button. This switches the display to incremental mode. Press the ZERO key. Any measurement now taken will be an incremental measurement. The display can be repeatedly zeroed (for incremental measurements) by pressing the ABS/INC button for one second. To return to the ABS coordinate system, press the ABS/INC button for 3 seconds.

Incrementing/Decrementing the Display

The PLUS or MINUS keys on the digital display are used to adjust a reading. For instance, if the display needs to read greater than its current value, use the PLUS key. Conversely, to reduce the current displayed reading, use the MINUS key. This function is used to preset a value in the system. When the display is in the LOCK mode these keys will either:

1. No longer function, preventing accidental adjustment of readings, or
2. They will be used for another function (pattern offset in ABS LOCK mode).

Note: When pressing the PLUS or MINUS keys, the display scrolls slowly for a couple seconds and then speeds up.

Reverse Scaling

When setting a zero point on ProScale, moving the scale in one direction will produce positive readings. Moving the scale past zero in the opposite direction will produce negative readings. Reverse scaling means changing the orientation so positive readings become negative and negative readings become positive. To reverse the readings, the position of JP3 (inside the display) must be changed. See the chart of Display Options for more information.

Auto Save

When power is turned off, ProScale remembers the current measurement and current mode of operation. When ProScale is turned back on, it continues where it left off. It's not necessary to zero the reading or change the mode. Also, keystrokes are not recognized when power is off, so accidental keystrokes will not damage the stored information.

Locking the Keypad

The display allows the keypad to be locked so the current settings can't be accidentally changed by depressing the ZERO, PLUS or MINUS keys. To lock the keypad proceed as follows:

1. While depressing and holding the ON/OFF key, momentarily press the MODE key.
2. Release the MODE key and then the ON/OFF key. The display should now indicate "LOCK" in the upper left corner.
3. Use the same procedure to UNLOCK the keypad.

NOTE: Locking the keypad may cause the PLUS and MINUS keys to function differently. (See "Pattern Adjustment".) The zero key will not function when the display is locked.

Pattern Adjustment

Whenever the readhead is disconnected from its power source, *or the display is turned off*, and the readhead is moved over a pattern joint, the displayed reading may be one or more patterns (\pm 430mm) in error when power is restored. This may also occur if the readhead is moved too quickly in Model 150/250 systems.

To correct the error, place the digital display in ABS LOCK mode and use the PLUS or MINUS keys to increment or decrement the reading until the proper reading is displayed. Using this procedure will result in NO LOSS OF ACCURACY to the system.

Hold

The current state of the display is "frozen" when the HOLD button is pressed, and remains "frozen" until the button is pressed again. When in hold, the display will display HOLD in the upper left corner, and no movements or keystrokes will be recognized. When HOLD is released, all pending keystrokes will be recognized. If the power is cycled, the HOLD will be cleared.

Note: The ProScale display will auto-detect an SPC device connected to the display and reconfigure the HOLD button to Data Send.

SPC (Statistical Process Control)

The data format and connector style of the ProScale SPC output is the same as Mitutoyo SPC. This is an industry standard that can be interfaced with most available SPC products including multiplexers, RS232 converters and PC plug-in boards. Data from the ProScale is sent to the SPC connector in either millimeters or decimal inches.

Accounting for Kerf

When a measurement needs to account for kerf, ProScale makes it easy to make the measurement without having to perform any calculations. The following is an example of how to account for kerf on a table saw. For other instruments in which kerf should be considered, vary this procedure accordingly.

1. Measure the kerf of the saw blade as accurately as possible.
2. Press the ABS/INC button on the Display to set display to INC.
3. Press the PLUS (or MINUS) key until the kerf measurement is displayed.
4. Press the ABS/INC button for one second to save this value into the display's memory.
5. After the first cut, press the ABS/INC button to compensate for kerf.
6. Press the ABS/INC button before each of the following cuts.
7. When finished cutting, press the ABS/INC button for 3 seconds to view the absolute distance from the saw blade.

Changing the Batteries

To change the batteries, remove the two screws holding the cover to the base of the display housing. Carefully pull off the cover. Remove the batteries. Reinstall new ones, noting the proper orientation shown in the battery compartment. Replace the cover and tighten the screws.

Note: DO NOT ATTEMPT TO BEND BATTERY CLIPS!

Mounting the Display

There are four small mounting holes in the back of the display which may be tapped for M2 or 4-40 screws. The display may also be mounted using double sided tape or Velcro.

1/4 DIN Panel Mount Displays



Power Supply

There are two versions of the 1/4 DIN Panel mounted displays. The first version requires power supplied from two "D" cell batteries (shipped with the display). The second version requires the installer to hook up power (24 volts, AC or DC) to the display.

Mounting the Display

A cutout must be made in the panel where the display is to be mounted. The cutout should measure at least 90mm x 90mm (3.6 x 3.6 inches). The cutout should measure no larger than 93mm x 93mm (3.7 x 3.7 inches).

The casing of the panel mount displays "sandwich" a panel between the front cover and the rear cover. The displays are designed to accommodate any panel thickness between 0.125" and 0.750".

Note: For any panel thinner than 0.125 inches, shorter screws must be used for the display casing. If shorter screws are not used, damage to the front cover will occur.

Changing the Measurement Readout:

Press the MODE key to change the measurement readout. The current measurement readout is saved when power is off. Readouts appear in the following order:

1. Millimeters.
2. Decimal inches.
3. 16ths of an inch, each bar in the display's upper right corner represents an additional $1/64^{\text{th}}$ of an inch.
4. 32nds of an inch, each bar in the display's upper right corner represents an additional $1/64^{\text{th}}$ of an inch.
5. 64ths of an inch.

Setting Zero

A zero point is easily established by pressing the ZERO key when the display is unlocked. All subsequent measurements will reflect distance from this point.

Incrementing/Decrementing the Display

The PLUS or MINUS keys on the digital display are used to adjust a reading. For instance, if the display should read greater than its current value, use the PLUS key. Conversely, to reduce the current displayed reading, use the MINUS key. This function is used to preset a value in the system. When the display is in the LOCK mode these keys will either:

1. No longer function, preventing accidental adjustment of readings, or
2. They will be used for another function (pattern offset in ABS LOCK mode).

Note: When pressing the PLUS or MINUS keys, the display scrolls slowly for a couple seconds and then speeds up.

Reverse Scaling

When setting a zero point on ProScale, moving the scale in one direction will produce positive readings. Moving the scale past zero in the opposite direction will produce negative readings. Reverse scaling means changing the orientation so the positive readings become negative and negative readings become positive. To reverse the readings, the position of a jumper (inside the display) must be changed. See the chart of Display Options for more information.

Auto Save

When power is turned off, ProScale remembers the current measurement and current mode of operation. When ProScale is turned back on, the user can continue where they left off. It's not necessary to zero the reading or change the mode. Also, keystrokes are not recognized when power is off, so accidental keystrokes will not damage the stored information.

Locking the Keypad

The keypad may be locked so the current settings can't be accidentally changed by depressing the ZERO, PLUS or MINUS keys. To lock the keypad proceed as follows:

1. While depressing and holding the ON/OFF key, momentarily press the MODE key.
2. Release the MODE key and then the ON/OFF key. The display should now indicate "LOCK" in the upper left corner.
3. Use the same procedure to UNLOCK the keypad.

Note: Locking the keypad may cause the PLUS and MINUS keys to function differently. (See "Pattern Adjustment".) The zero key will not function when the display is locked.

Pattern Adjustment (Battery Powered Display Only)

Whenever the readhead is disconnected from its power source, *or the display is turned off*, and the readhead is moved over a pattern joint, the displayed reading may be one or more patterns ($\pm 430\text{mm}$) in error when power is restored. This may also occur if the readhead is moved too quickly in Model 150/250 systems.

To correct the error, place the digital display in ABS LOCK mode and use the PLUS or MINUS keys to increment or decrement the reading until the proper reading is displayed. Using this procedure will result in NO LOSS OF ACCURACY to the system.

Programmable (Including Externally Powered Displays)



Display Programming

This display must be programmed for the user's preferences before use. All display programming is done through the keypad on the display face. All programming parameters are saved in memory and are preserved in the event of power failure. To enter programming, press and hold the MODE key, then press the ZERO key. The display will show the following:

1	0
---	---

Note: If no change occurs to the display, the display programming option has been disabled. To enable the programming options, JP1 inside the display must be set to the B position.

The left-most digit represents the programming option (1 to 9). Each of these options represents a different program parameter. The number on the right represents the current value of the parameter. To change the parameter value, press the PLUS/MINUS key to increase/decrease the displayed value. (Each parameter has a limited range and cannot be exceeded by additional presses of the PLUS or MINUS key).

To move to the next programming parameter, momentarily press the MODE key. The programming parameter (left side) will increase by one,

and show the next parameter value (right side). After the ninth parameter, pressing the MODE key will restart the parameter list at 1. To exit the programming mode, press and hold the MODE key, then press the ZERO key. The programming parameters and the valid parameter values are shown in the following chart:

Parameter Option	Valid Parameter Values
Option 1 Measurement Units	0 = millimeters 1 = decimal inches 2 = Fractions, 16ths 3 = Fractions, 32nds 4 = Fractions, 64ths
Option 2: Enable/Disable Offsets	0 = Offsets can not be entered 1 = Offsets can be entered
Option 3: Enable/Disable Multi-Pattern Scales (Must be enabled for scales over 17")	0 = Multiple Scale Patterns not recognized 1 = Multiple Scale Patterns allowed
Option 4: Encoder Direction (changes sign)	0 = Positive readings 1 = Negative readings
Option 5: Enable/Disable HOLD Feature	0 = HOLD feature is disabled 1 = HOLD feature is enabled
Option 6: Automatic Power-off Timer	0 = Automatic Power-off is disabled 1-255 Number of minutes until power-off
Option 7: INC Mode Operation	0 = Disables INC mode; ABS mode only 1 = Allows kerf values in INC mode 2 = Uses INC mode as 2 nd coordinate system
Option 8: Scaling Multiplier	Scaling multiplier can be from 0.01 to 99.999 Default value is 1.000
Option 9: Position Change Needed for Wake-up (must be set in mm)	Valid range is .1mm to 99.9mm Default is 2.0mm

Setting ABS Position

When the display is in ABS mode (indicated by ABS in the upper left corner of the display), a zero point is established by pressing the ZERO key. All subsequent absolute measurements will reflect distance from this point. The display should be locked to prevent accidental resetting.

Setting INC Position

Momentarily press the MODE key. This switches the display to incremental mode. Press the ZERO key. Any measurement now taken will be an incremental measurement. The display can be repeatedly re-zeroed (for incremental measurements) by pressing the MODE key (for

one second). To return to the ABS coordinate system, press the MODE key twice within 2 seconds.

Note: If disabled, INC mode cannot be activated using the MODE key. To set a kerf value (for repeating cuts), press the plus, zero and minus keys (with LOCK off), then press the MODE key for one second.

In the secondary coordinate system mode, INC mode operates exactly like ABS mode. This can be useful in applications (like vertical panel saws) where two positions on the same axis are based on one readhead's movement. Press the MODE key twice within 2 seconds to return the display back to the ABS mode.

Locking the ABS/INC values

The ABS or INC modes can be locked/unlocked independently of each other by depressing and holding the MODE key for 2 seconds.

Note: If option 2 is disabled in the programming mode, both ABS and INC modes will always be in the locked state.

Pattern Adjustment (Multi-Pattern Mode)

Whenever the readhead is disconnected from its power source, *or the display is turned off*, and the readhead is moved over a pattern joint, the displayed reading may be one or more patterns ($\pm 430\text{mm}$) in error when power is restored. This may also occur if the readhead is moved too quickly in Model 150/250 systems.

To correct the error, first make sure the display is **not** in LOCK mode. Press and hold the MODE key along with either the PLUS or MINUS keys to modify the pattern offset by one pattern length (430mm). Using this procedure will result in NO LOSS OF ACCURACY to the system.

Position HOLD

The current state of the display may be "frozen" by activating the HOLD function. The HOLD function is activated by momentarily pressing the PLUS key **while the LOCK feature is on**. When in hold, the display will display HOLD in the upper left corner. If the power is cycled, the HOLD will be cleared. To turn off the HOLD feature, momentarily press the PLUS key again.

Summary of Digital Display Keypad Functions

On/Off: Turns display on or off with each depression.

MODE: Function varies depending on operating state:

1. Selects absolute (ABS) or incremental (INC) mode of operation during normal use by pressing for one second.
2. Press and hold for two seconds to lock the display.
3. Advances to next programming option while in programming mode.
4. Acts as a "SHIFT" key to execute special operations:
 - a) MODE *and* ZERO = programming mode entry/exit.
 - b) MODE *and* PLUS = add pattern in multi-pattern mode.
 - c) MODE *and* MINUS = subtract pattern in multi-pattern mode.

+ (PLUS):

1. Adds to position value in normal use.
 2. Increments option value while in program mode.
 3. Enables HOLD feature when LOCK is enabled.
- Zero:** Sets displayed position to zero in either ABS or INC (when display is NOT locked).

- (Minus):

1. Subtracts from position value in normal use.
2. Decrements option value while in program mode.

Changing the Batteries (If battery equipped.)

To change the batteries, remove the two screws holding the cover to the base of the display housing. Carefully pull off the cover. Remove the batteries. Reinstall new ones, noting the proper orientation shown in the battery compartment. Replace the cover and tighten the screws.

Note: DO NOT ATTEMPT TO BEND BATTERY CLIPS!

Mounting the Display

There are four small mounting holes in the back of the display which may be tapped for M2 or 4-40 screws. The display may also be mounted using double sided tape or Velcro.

Installation Notes

Scales

Scales used for individual products should never be mixed. Try to avoid drilling through the green portion of the scale. Any portion of the green which is drilled will not operate.

Note: Shortening Model 150 or Model 250 scales is not advised. Contact your supplier or Accurate Technology to order special length scales.

To shorten the incremental scales for an application, follow these steps. The scale is embedded with stainless-steel wires that could be damaged if not cut properly.

1. Use a grinder (such as a Moto Tool®) to grind through the wires embedded in the sides of the scale.
2. Using a hacksaw, cut through the aluminum extrusion.
3. Use a file or sanding tool to chamfer the cut end to the specifications shown in the illustration.
4. Remove all burrs.
5. Test the shortened scale by sliding a readhead on. There should not be any binding.

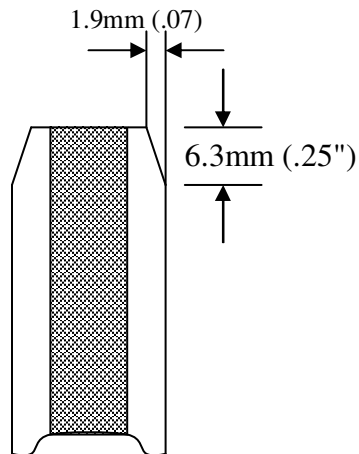

Readheads

Readheads used for individual products should **NEVER** be mixed. Avoid making extension cables if possible. If a different cable length is required, contact your supplier or Accurate Technology, Inc. The pressure exerted on the readhead by the guide clip should never cause the circuit board to press against the green strip on the scale, as this will quickly wear out both components. See the diagram on page 19 for more information about proper guide clip spacing.

Displays

The tables below show display options that may be configured by the installer. When shipped, displays are set to allow the maximum number of options at power-up. To limit the available options, change the positions of the internal jumpers. When changing jumpers, first note their factory positions.

Lifting the plastic connector off its two posts and repositioning to another two posts changes the jumper's position. The center post for each jumper setting is always common. *The tables below show options for displays.* **BOLD** type indicates factory default settings.

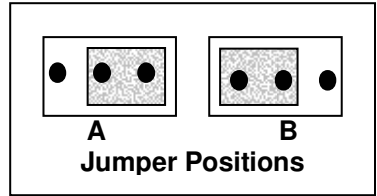

Incremental Display
Basic Display
Standard Display

Part #701-1495-002
Part #701-1495-001
Part # 701-1500-001



701-1495-00x



701-1500-001

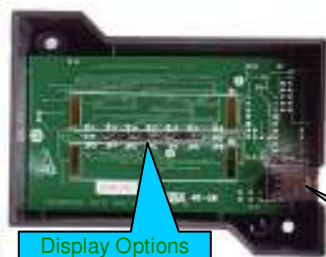

Display Options
Jumpers

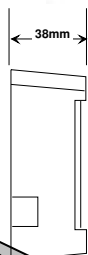

ReadHead
Connector

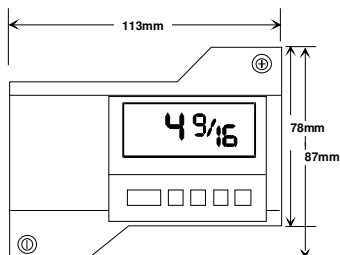

Jumper	Position	Function	Notes
JP1	A	Increased resolution (Decimal inch mode only)	Display format: XX.XXXX in. (99 inch limit)
	B	Normal resolution	Display format: XXX.XXX in (394 inch limit) XXXX.XX mm(9999 mm limit)
JP3	A	Sets scaling direction	Positive readings
	B	Sets scaling direction	Negative readings
JP4	A	Normal resolution	Display format: XXX.XXX in (394 inch limit) XXXX.XX mm (9999 mm limit)
	B	Reduced resolution (Decimal and mm modes)	Display format: XXX.XX in (394 inch limit) XXXX.X mm (9999 mm limit)
JP5	A	Normal display	Display format: XXX.XXX in (394 inch limit) XXXX.XX mm (9999 mm limit)
	B	Centimeters, decimal inches and fractions	Display format: XX.XXXX in (99 inch limit) XXX.XXX cm (999 cm limit)
JP7	A	Scales shorter than 400mm	Default for Model 150-10
	B	Scales longer than 400mm	Default for all other systems
JP2, JP6, JP8		<i>Factory Settings</i>	

SPC Display Part # 701-1505-002

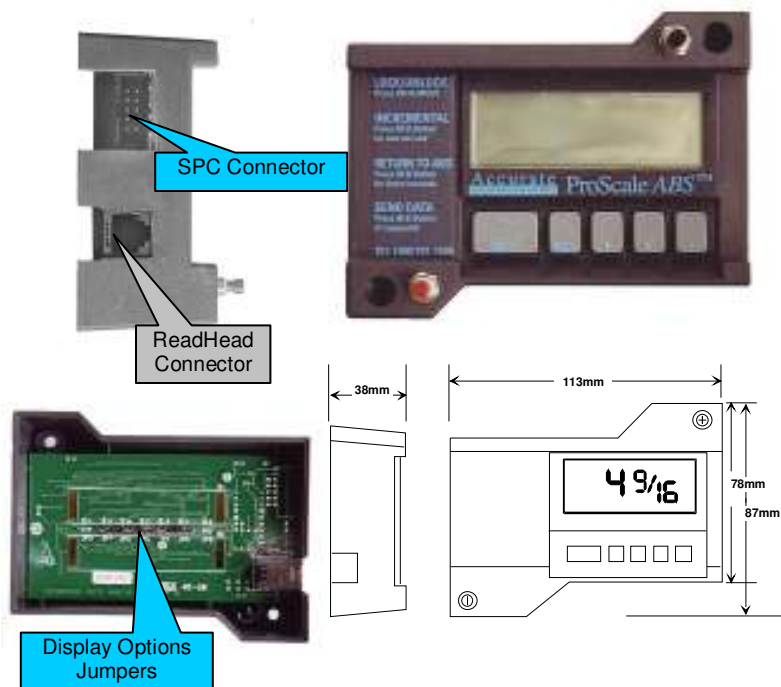

Jumper	Position	Function	Notes
JP1	A	Increased resolution (Decimal inch mode only)	Display format: XX.XXXX in. (99 inch limit)
	B	Normal resolution	Display format: XXX.XXX in (394 inch limit) XXX.XX mm(9999 mm limit)
JP3	A	Sets scaling direction	Positive readings
	B	Sets scaling direction	Negative readings
JP4	A	Normal resolution	Display format: XXX.XXX in (394 inch limit) XXX.XX mm (9999 mm limit)
	B	Reduced resolution (Decimal and mm modes)	Display format: XXX.XX in (394 inch limit) XXX.X mm (9999 mm limit)
JP5	A	Normal display	Display format: XXX.XXX in (394 inch limit) XXX.XX mm (9999 mm limit)
	B	Centimeters, decimal inches and fractions	Display format: XX.XXXX in (99 inch limit) XXX.XXX cm (999 cm limit)
JP7	A	Scales shorter than 400mm	Default for Model 150-10
	B	Scales longer than 400mm	Default for all other systems
JP2, JP6, JP8		<i>Factory Settings</i>	

Programmable Battery Display
Programmable Ext. Pwr. Display

701-1115-001
701-1115-002



Front & Side view of external power connector (if equipped)

This display must be programmed for preferences before use. All programming is done through the keypad on the display face, and is saved in non-volatile memory

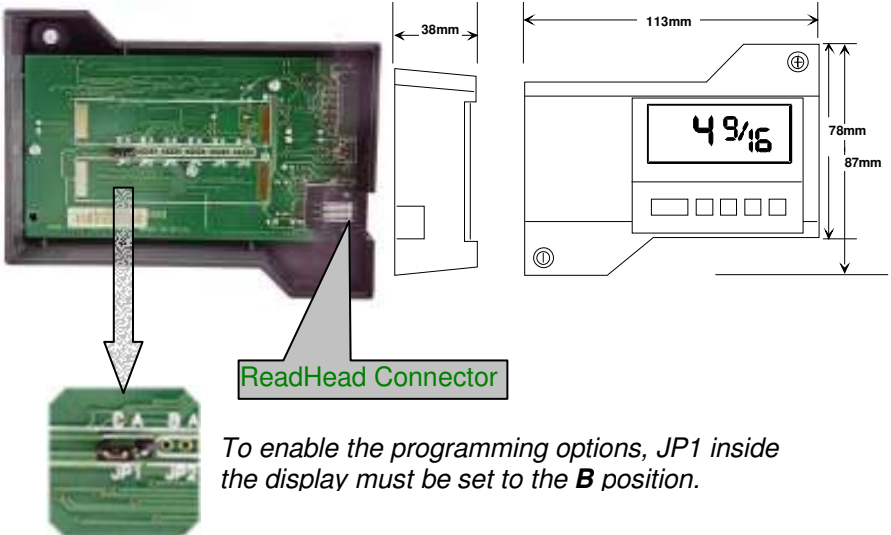

To enable the programming options, JP1 inside the display must be set to the **B** position.

Panel Mount Display Part # 701-1525-001

¼ DIN Panel Mount Display (105 mm square)

SIZE: Cutout dimensions should measure at least 90mm x 90mm and no larger than 93mm x 93mm. The displays will fit panel thickness between 3mm and 19mm.

POWER:
24 VAC or 24 VDC @
100mA

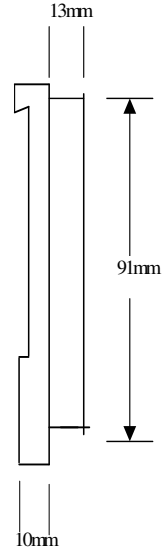

Display Options
Jumpers

SPC
Connector

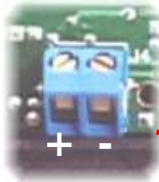

Power
Connector

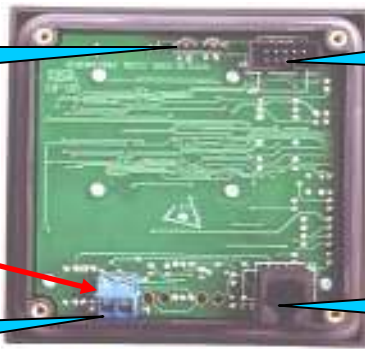

ReadHead
Connector

24 volt powered panel mount Display Option Jumpers:

Jumper	Position	Function	Notes
JP1	A	No fractions.	Decimal inches and mm only.
	B	Fractions available.	Decimal inches, mm, and fractions all available.
JP2	A	Sets scaling direction	Positive Vs Negative readings
	B	Sets scaling direction	Negative Vs Positive readings

Panel Mount Display Part # 701-1550-002

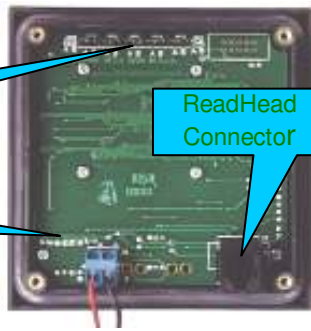
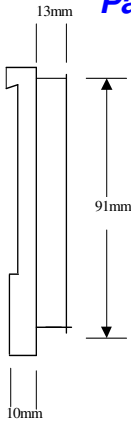

¼ DIN Panel Mount Display
(105 mm square)

SIZE: Cutout dimensions should measure at least 90mm x 90mm and no larger than 93mm x 93mm. The displays will fit panel thickness between 3mm and 19mm.

Jumper	Position	Function	Notes
JP1	A	Increased resolution (Decimal inch mode only)	Display format: XX.XXXX in. (99 inch limit)
	B	Normal resolution	Display format: XXX.XXX in (394 inch limit) XXXX.XX mm (9999 mm limit)
JP3	A	Sets scaling direction	Positive readings
	B	Sets scaling direction	Negative readings
JP4	A	Normal resolution	Display format: XXX.XXX in (394 inch limit) XXXX.XX mm (9999 mm limit)
	B	Reduced resolution (Decimal and mm modes)	Display format: XXX.XX in (394 inch limit) XXXX.X mm (9999 mm limit)
JP5	A	Normal display	Display format: XXX.XXX in (394 inch limit) XXXX.XX mm (9999 mm limit)
	B	Centimeters, decimal inches and fractions	Display format: XX.XXXX in (99 inch limit) XX.XXX cm (999 cm limit)
JP7	A	Scales shorter than 400mm	Default for Model 150-10
	B	Scales longer than 400mm	Default for all other systems
JP2, JP6, JP8		<i>Factory Settings</i>	

ProPower DC Power Supply Part # 901-0200-001

ProPower is a multi-output DC power supply for use with the ProScale™ line of electronic measurement products.

ProPower can be used to power up to 50 ProScale LCD displays or 8 ProScale LED displays



Physical: Width 200mm Height 200mm Depth 120mm

Specifications

Input Power

- 110-120 VAC 60Hz.
- 220-240 VAC 50Hz.
- 24 VAC 50/60Hz.
- 24 VDC (3.3 volt DC output mode only).
- 6 volt dry cell battery only operation (3.3 volt DC output mode only).

Output Power

- Regulated 24 VDC @ 500 mA.
- Regulated 3.3 VDC @ 100 mA.
- Regulated 6 VDC @ 100mA. to charge sealed lead acid battery.
- Solid-state over-current protection on all outputs.
- Transformer secondary over-current protection.
- Multi-stage transient voltage protection.
- 24 VDC and 3.3 VDC LED operation indicators.
- Industrial enclosure rated: NEMA 4, CSA LR 59132, IP 66

For more detailed operation of ProPower, See ProPower Manual.

Frequently Asked Questions

Why is there an “Err 2” message on the display?

If the read head is off the scale, or the readhead cable is unplugged from the digital display, an “Err 2” will appear on the display. To clear error:

1. Be sure the readhead is on the scale.
2. Unplug the connector from the display for one second.
3. Reconnect the readhead cable to the digital display.

Pressing ZERO, PLUS, or MINUS keys has no effect or causes the display to change approximately 17 inches:

The keypad is locked. To unlock the keypad, momentarily press and release the MODE key while holding down the ON/OFF key. The ABS display is locked in the ABS mode.

The battery clips seem to be very loose. Is this normal?

Yes. DO NOT attempt to bend these clips or wedge anything between them and the case. These clips are designed to expand when the two case halves are screwed together.

Can I mount the scale/read head without the flex link/guide clip?

The flex link and guide clip serve to provide an accurate method of transferring the movement of the moving part to the read head, while also absorbing any stresses that may occur. If they are not used, the warranty is voided.

The display reads numbers but they seem to be random.

Be sure the readhead is oriented correctly on the scale. One end of the scale is black. Be sure that the arrow on the readhead sticker is pointed in the correct direction.

Pressing the MODE key has no effect.

The display is in the INC mode. Return to ABS mode by depressing and holding red button for three seconds.

The display does not change as the scale/readhead moves.

The display is in the HOLD mode. Press & release the Hold (black) button.

Product Communication:

ProScale's electrical interface allows the readhead position to be read by a computer or other instrument. Interface diagrams are available upon request.

Error Codes & Factory Service

ProScale warns if an error occurs by displaying "Err" plus a number on the display. If error code 0, 1, 2, 3, 5, 6, 7, or 8 is displayed:

1. Check to be sure the readhead is on the scale.
2. Check all connections and cable for damage.
3. If the readhead is on the scale and all connections are good, unplug the readhead from the display , wait 3 seconds, and reinstall it.

If error code 4 is displayed, the display is trying to display fractions over 99 63/64". Switch to a decimal readout or press ZERO (and recalibrate) if this value is incorrect.

For further assistance, contact your supplier, or Accurate Technology. When calling for factory service, please have as much information about your product on-hand. If possible, please have the following information:

1. Product name.
2. Any modification to the product.
3. The date of product purchase.
4. Detailed information about the problem, such as when, where, and how the problem occurs, and the machinery being used nearby.

Abbe Error

Abbe error is a condition which may not be visible to the human eye, but will affect linear measurements. Be sure to take precautions when installing ProScale in order to eliminate the possibility for Abbe error.

Abbe error refers to a linear error caused by the combination of an angular error and a dimensional offset between the sample and the measuring system. It is important to understand that the information the encoder is providing is **only the position of the readhead on the scale**.

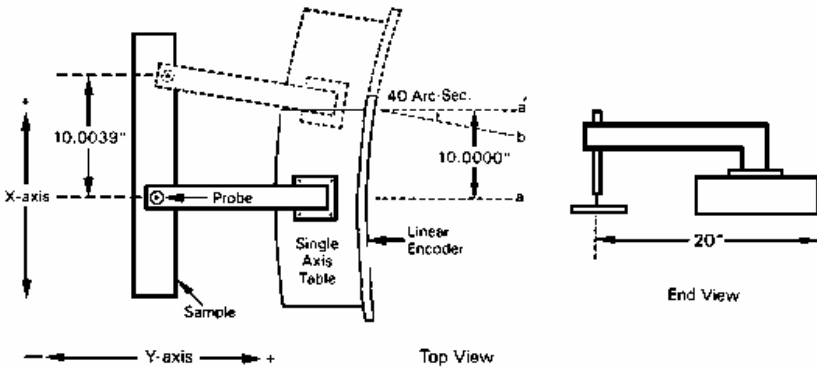

To illustrate this, see the figure, which shows a linear measuring device. (The apparent distortion in the measuring device is intentional - for this example - to show the measuring device with a curvature in its mounting.)

Suppose the curvature in the figure is sufficient to produce an angle of 40 arc-seconds. If the measuring device moves 10 inches, the probe will be found to have moved 10.0039 inches, resulting in an error of +0.0039 inches. Abbe error could be lessened by moving the measuring system closer to the sample. This effectively solves one half of the Abbe error problem (offset) and leaves only the angular mounting problem to be solved. Angular error can best be countered through proper design and placement of the linear scale. Sources of angular error include:

1. Mounting the linear scale to an imperfectly flat surface.
2. Mounting the linear scale to an imperfectly straight surface.
3. Curvature of ways (or linear bearings) used to measure the sample.
4. Contaminants between the probe and item being measured.
5. Friction in any part(s) of the measuring device.

A

Abbe error, 26
ABS Position, 38
absolute, 7
absolute systems, 7
Accuracy, 12
Auto Save, 36

B

Batteries, 37
BATTERY CLIPS, 48
Battery Life:, 12
Bearing Adjustment, 32

C

Calibration, 16, 19
connector link, 14
Corner-To-Corner Measuring, 28

D

Decrementing, 36
DISPLAY, 6
Display Description, 33
Display Range, 12

E

Edge-To-Edge Measuring, 28
electrical interface, 59
Err 2, 58
error code, 59
extension cables, 49

F

fence, 22
Frequently Asked Questions, 58

G

guide clip, 19

H

Hold, 40
Hole-To-Hole Measuring, 29

I

INC Position, 39
Incremental, 7
Incrementing, 36
Introduction, 5

J

jaws, 30
jumpers, 51

K

Kerf, 41

L

linear error, 60
Locking, 47
Locking the Keypad, 36

M

Maintenance, 16
Measurement Kits, 10
Measurement Table Kit, 25
Minus, 48
MODE, 35, 48
Model 150, 10
Model 250, 10
Mounting, 14, 17

O

offset, 7
Output Format, 13

P

pattern, 7
Pattern Adjustment, 37

PLUS, 48
ProCaliper, 10, 30
ProCase, 11
Programming, 45
ProKits, 11, 24
ProLine, 11
ProPanel, 10, 28
ProPower, 11
ProScale Model 150, 14
ProScale Model 250, 17
ProSet, 11
ProStand, 11
ProStop, 10, 21
ProTable, 11
ProTOOL, 11

R

random numbers, 58
READHEAD, 6
Relative Measurements, 32
Repeatability, 12

Reverse Scaling, 36

S

SCALE, 6
Setting Zero, 35
shorten, 49
Slew Rate, 12
sliding assembly, 25
SPC, 41
Specifications, 12

T

Table of Contents, 3
tearout, 21

W

Warranty, 2
wing, 23