

PROKIT 590 MEASURING SYSTEM
RANGES UP TO 16 FEET
NOTE: SYSTEM DOES NOT NEED
TO START AT ZERO (IT CAN BE
OFFSET FROM ZERO)

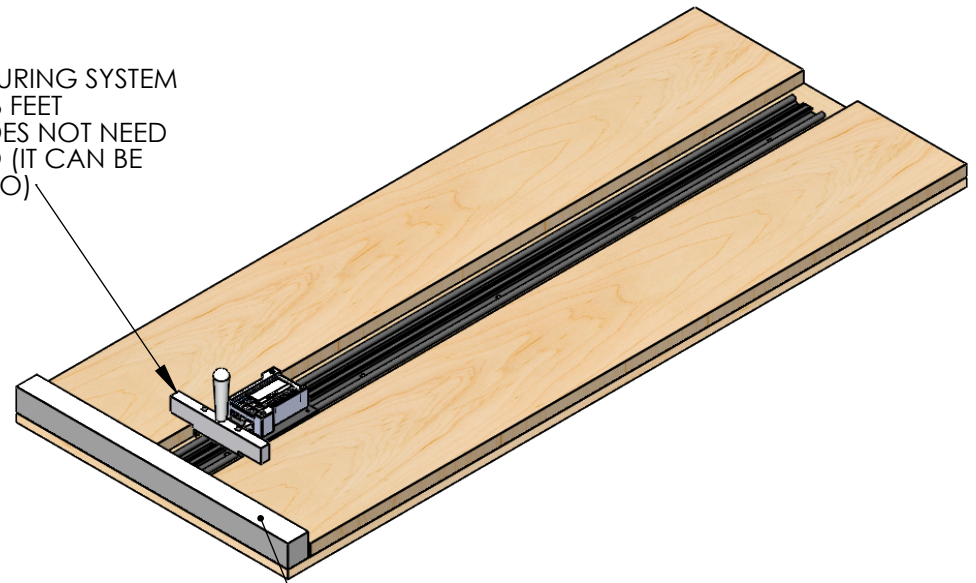
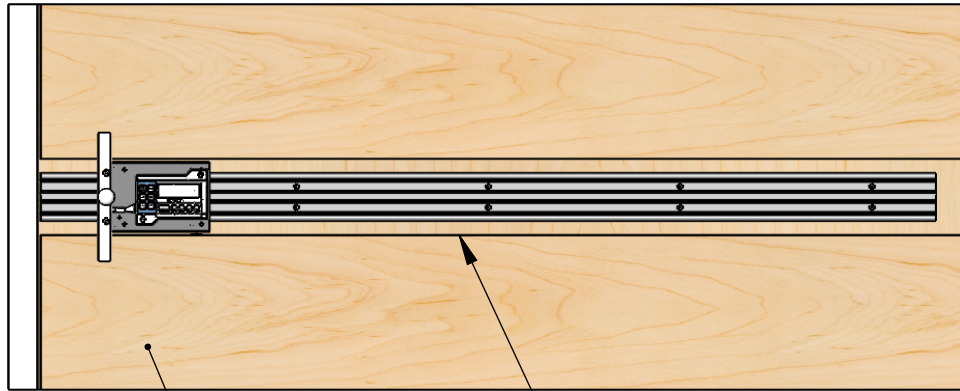

RECOMMENDED RECESS IS 4.75 X 1.0 INCHES
DIGITAL SCALE IS 8 INCHES LONGER THAN RANGE

DESIGN YOUR OWN FIXED JAW/BACKSTOP:
THE SIZE, SHAPE AND MATERIAL SHOULD BE
SELECTED TO MATCH YOUR NEEDS

THIS MATERIAL CAN BE WOOD, PLASTIC, METAL, ETC.
REMEMBER THAT THE MATERIAL SIZE WILL CHANGE WITH TEMPERATURE;
(A TEMPERATURE MONITOR AND CTE CORRECTION FACTORS
ARE BUILT INTO THE DIGITAL READOUT.)

THE MEASURING SYSTEM IS RECESSED BELOW UPPER SURFACE
(TO PROTECT THE DIGITAL SCALE)
PARTS TO BE MEASURED ARE MEASURED BETWEEN JAWS

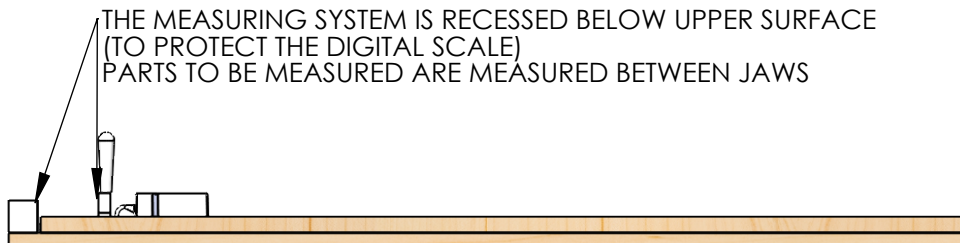

1.000 AS SHOWN

MATERIAL ADDED
EXISTING TABLE

