

ProScale Model 150G: Capacitive Absolute Encoder system

Systems with Part Numbers **901-15***ll-dro-cab-G*,
 Where *ll* is measuring length, *dro* is the digital
 readout choice, and *cab* is the length of the encoder's
 cable.

**TECHNICAL DATA
 SHEET**

GENERAL INFORMATION

- Model 150G is a linear encoder with fixed gap between encoder and scale. No moving gears or rollers to wear out, and no alignment is needed to set the encoder to scale distance.
- Output resolutions is 0.01mm
- Accuracy is not affected by alignment of installation.
- Easy installation onto nearly any machine or measuring system.
- Model 150G is not affected by magnets, static electricity, or most motor transients.
- Will not lose position if power or signal are interrupted.
- 3-year warranty.
- Made in USA.



MECHANICAL:

- Anodized aluminum scale has a tapped mounting hole for a #10 machine screw.
- Sensor gap is set at the factory and never needs adjustment.
- Cable lengths from 4 inches to 360 inches.
- A Connector Link is provided for connecting motion of the scale to moving part on your machine. The Link compensates for minor yaw, pitch, roll, and linear alignment issues.
- Excellent vibration resistance.
- Operating temperature range: 30-120 F
- Digital scale is 4.25 inches longer than measuring range.

ELECTRICAL:

- Six conductor cable from the encoder is shielded.
- Cable is very flexible.
- Cable has strain reliefs at both ends.
- This system can be used with battery powered readouts or with externally powered readouts.
- Capacitive technology is not affected by magnets or any non-conductive debris.
- **Absolute** technology is not affected by static electricity, most transients, or power loss.
- Slew rates up to 10 inches/second. (Higher rates available on request.)
- Output signal is Digimatic, same as most digital calipers used worldwide.

ABOUT ACCURACY:

Accuracy of Model 150G is +/- .002" when installed correctly.

Temperature can affect accuracy, and should be considered with very long measuring ranges, or if large temperature variation is expected.

The accuracy can be further improved after installation by employing linear, non-linear, and/or temperature compensation (features available on select ProScale readouts).

DIMENSIONS:

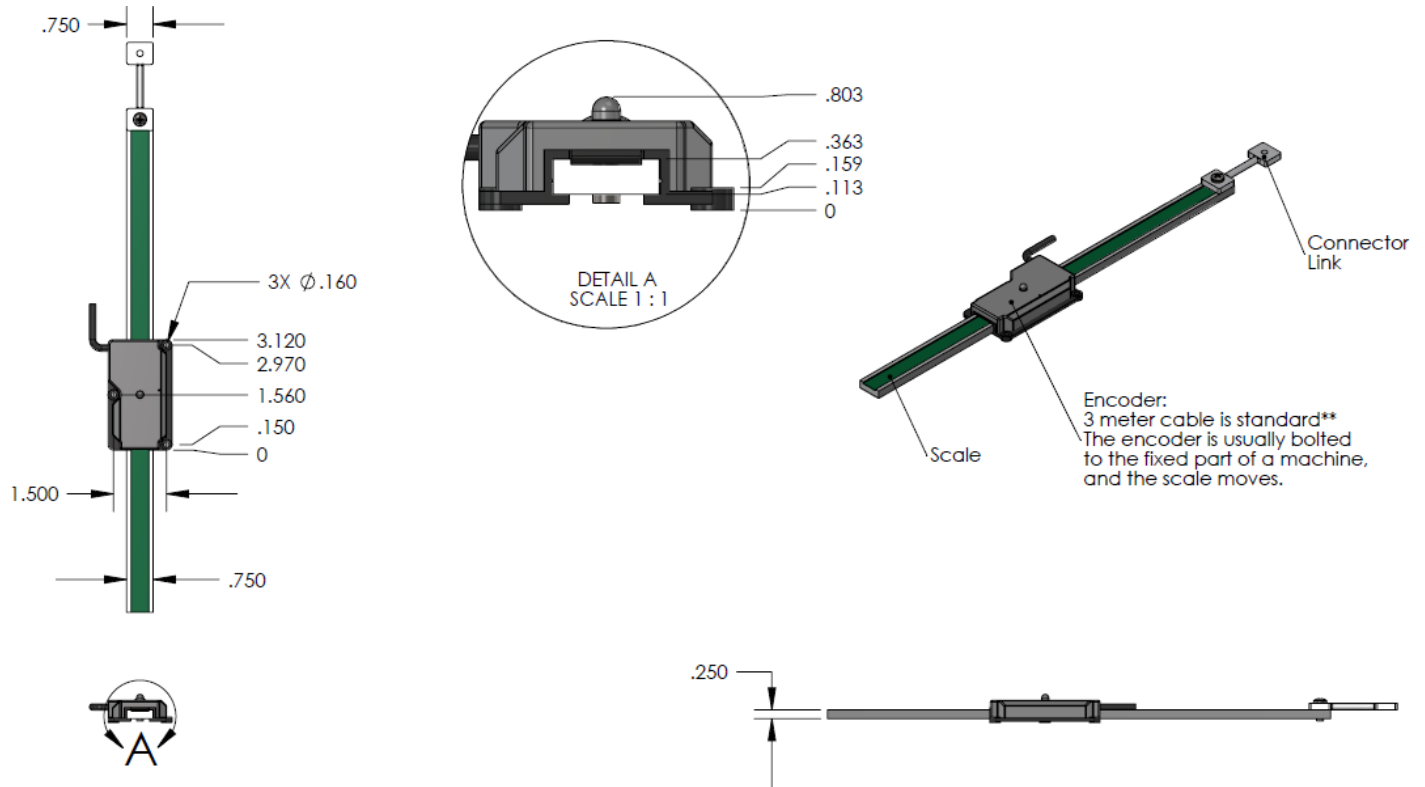

3D CAD (STEP and IGS) files are available at www.proscale.com or by email on request.

INSTALLATION TOLERANCES (with connector link):

- Roll: +/- 4 degrees
- Pitch: +/- 3 degrees
- Yaw: +/- 4 degrees

HOW TO ORDER:

1. Determine measuring range required. Find the next larger stock size (see below).
2. Determine how long a cable is needed.
3. Determine which ProScale readout is needed.

WHERE TO ORDER:

- From factory by calling 1-828-654-7920
- From website: www.proscale.com
- From distributors – see list at www.proscale.com/where-to-buy