

ProScale™ Universal Mounting Kit Installation Instructions

This Mounting Kit provides components for mounting ProScale Measuring Systems in a wide variety of applications. The kit contains components to mount the Encoder and Scale assembly on a tool or other surface. The kit also contains the hardware necessary to mount the Readout on any flat surface and adjust it to the desired viewing angle.

NOTE: These installation instructions provide suggestions for using the Universal Mounting Kit in a *typical* application.

SAFETY WARNING

To avoid injury: Before installing ProScale on a machine, turn off the machine and disconnect it from its power source.

This kit contains the following parts:

Quantity	Description	Use
2	10-32 x ½" Screws	Hold right angle brackets together
2	10-32 x 5/8" Screws	Hold right angle assembly to connector link
4	10-32 Kep Nuts	Nuts for right angle bracket assembly
3	6-32 x ½" Screws	Mount Encoder to Encoder bracket
3	6-32 Kep Nuts	Nuts for Encoder bracket assembly
4	4-40 Self-Tapping Screws	Mount Readout hinge to Readout
4	Hinge Mounting Screw	Mount hinge to mounting surface

1	Readout Mounting Hinge	Holds Digital Readout
---	------------------------	-----------------------



2	Right Angle Brackets	Mount connector link to machine
---	----------------------	---------------------------------



1	Encoder bracket	Mount Encoder to machine
---	-----------------	--------------------------

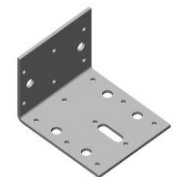

Installing the Readout Mounting Hinge:

The Readout mounts on a hinge, which allows it to be adjusted by the user to any angle for maximum ease of use.

CAUTION! Take special care while installing the Readout to avoid routing the cable in a manner that would leave it too loose, too tight, or prone to damage from moving parts of a machine.

1. Determine a mounting location that will allow the Readout to be easily seen. Be sure your location does not interfere with the routing of the Encoder cable.
2. Attach one side of the mounting hinge to the Readout using four 4-40 self tapping screws. Carefully tighten the screws; do not over tighten.

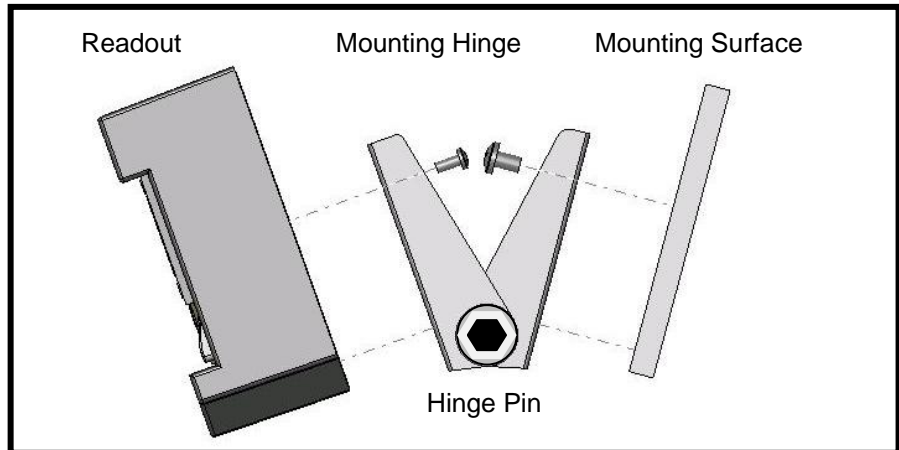

3. Use the Hinge Mounting Screws (8-32 x ¼") to mount the other side of the hinge to the mounting location determined earlier. To adjust the angle of the hinge, loosen the hinge pins with an M5 hexdriver and adjust to the desired angle. Retighten the hinge pins.

Installing the Encoder:

(Several sets of holes have been drilled through the encoder bracket, allowing both the bracket and the Encoder to be mounted in a variety of horizontal or vertical positions.)

1. Mount the Encoder in the desired location on the encoder bracket, using the 6-32 x ½" screws and nuts.
2. Determine a mounting location for the encoder bracket. Position the bracket in a location that allows the Scale to be inserted and moved freely through the encoder. Remember, the Scale is attached via the connector link to the moving part of a machine/device.

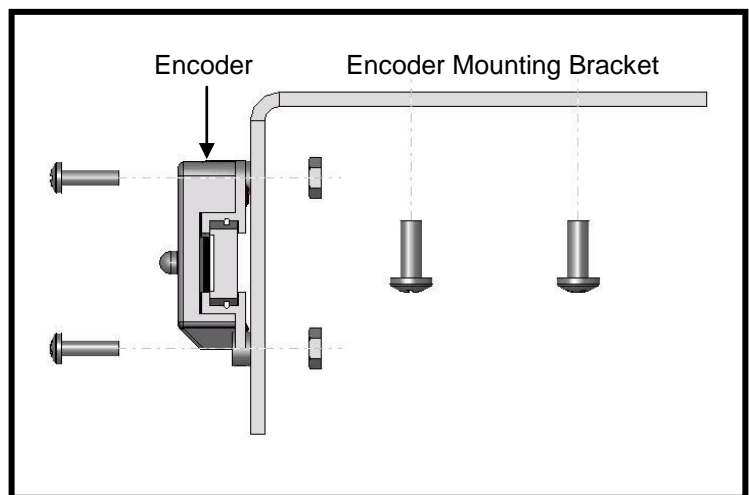

3. Mount the side of the bracket without the Encoder. Because of the wide variety of possible mounting surfaces and mounting positions, this step requires you to choose the best screws/nuts to mount the bracket.

Installing the Scale Assembly:

1. Determine a mounting location that will allow the Scale assembly to slide easily when inserted into the Encoder. The Scale assembly is mounted to the moving part of the machine/device via the connector link.

2. Assemble the right angle brackets using the 10-32 x 1/2" screws and nuts. The length of the brackets can be

adjusted by loosening the screws, sliding the brackets to the desired length, and re-tightening the screws. One example is shown in the figure above.

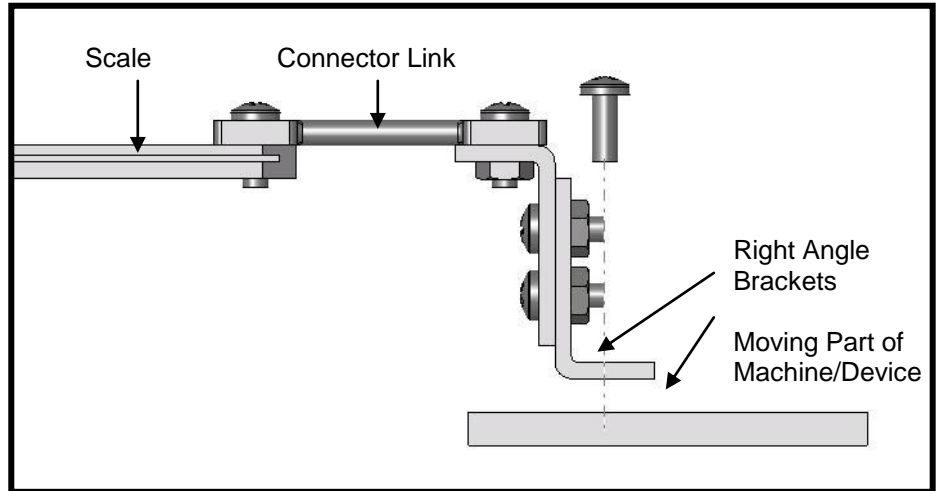

3. Attach one end of the right angle bracket assembly to the bottom of the connector link.

4. Double check the mounting position by inserting the Scale assembly into the Encoder and moving the Scale while temporarily fastening it to the moving part of the machine.

5. Attach the Scale assembly to the mounting position you just confirmed. Again, because of the wide variety of mounting surfaces and mounting positions, you must provide the necessary hardware to mount the Scale assembly.

Calibration of ProScale:

(Be sure to program your Readout first! See the Readout Operation Manual for more information)

1. With the machine/device locked in position, process/measure a small part.

2. Measure the part with the most precise measuring tool available and note the measurement.

3. Without moving the measuring system -Press the DATUM key on the Readout.

4. Use the PLUS and/or MINUS keys to enter the measured value into the Readout.

5. While depressing the ON/OFF key, press and release (in less than a second) the UNITS key. Release the ON/OFF key. The keyboard is now 'Locked". It can be unlocked by repeating this procedure.

NOTE: See the Operation Manual for your Readout for additional information regarding setting a reference, calibration and 'locking' options.

Troubleshooting:

Check the alignment of the Scale. Alignment *will* affect measurements over larger distances. Check the mounting of all components. Any loose bolts can allow for “slop” in measurement or position.

What does **no Enc mean?**

If the Encoder is off the Scale, or the Encoder cable is unplugged from the Readout, **no Enc** will appear on the LCD. To clear:

1. Be sure the Encoder is on the Scale and properly oriented.
2. Unplug the Encoder from the Readout for one second and then reconnect the Encoder.
3. Connect the Encoder to the Readout.

What does **b FAIL mean?**

When the readout displays this message it means the battery voltage has dropped to a level where reliable operation is no longer possible. Install a new battery to clear this message.

What does **P FAIL mean?**

When the readout displays this message it means the battery voltage has dropped to a level where reliable programming is not possible. Install new battery to clear this message.

The Readout numbers appear to be random. (Model 150, 250 & 950)

Be sure the Encoder is oriented correctly on the Scale. One end of the Scale is marked black; be sure that the arrow on the Encoder is pointed in this direction.

The Readout does not change, or changes very little, as it moves.

1. The Readout is in the HOLD mode.
2. The Encoder is on the Scale backwards. (Model 150, 250 & 950)
3. The Scaling factor is set very low.